

# Smart Home

How Home Automation Works and what it  
can do

Chris Chambers  
November 14, 2004

## **Introduction**

In 2003 68.3% of all American families owned a house. [4] Owning a house has many benefits and many homeowners see their homes as their sanctuaries, the place where they can relax and be themselves. But, it also takes a lot of work. There is always yard work to be done, the carpet to vacuum, the toilet to scrub, the kitchen to clean, or bills to pay.

Many homeowners say that even with all of these chores owning a house is worth it, but imagine if the house was smart enough to take care of all the chores, imagine a house that would vacuum the carpet, do the yard work, and scrub the toilet. Imagine a house where all the owner has to do is sit down and relax, spend time with his/her family, and enjoy not having to do the mundane chores of housework.

Many might say this sounds crazy. How can a house vacuum the carpet? How can a house clean itself? However, not only is it possible, Homes such as these are being designed and built right now. These new homes, called Smart Homes, are defined as a house that is networked together in some manner. This network is usually run by a central computer and will tie together the appliances, the light switches, and everything in the house.

## **How it works**

A fully functional smart house will need two things that are different from the house of today, a central computer that will manage the network of appliances and household items, and special wiring. [6]

### **Central Computer**

A smart house is basically a network of appliances, light switches and various assorted items communicating together so that the house will operate a lot more efficiently, and smoothly. To run this network a computer is required. In many cases this is a separate computer that is used as only the network controller but there are several designs where a personal computer can be used for this purpose.

The owner of the home can then access this computer either through an interface in the house, remotely, or by directly accessing the computer, and turn on all of the lights, close the window blinds, and many other tasks. The computer does this by taking advantage of the special wiring that is installed in a smart house.

### **Special Wiring**

The house of today is wired very simply, the switch is connected to the light bulb or appliance by a wire, and the signal is sent through the wire when the switch is toggled. The diagram below is a very simple illustration of this type of wiring.

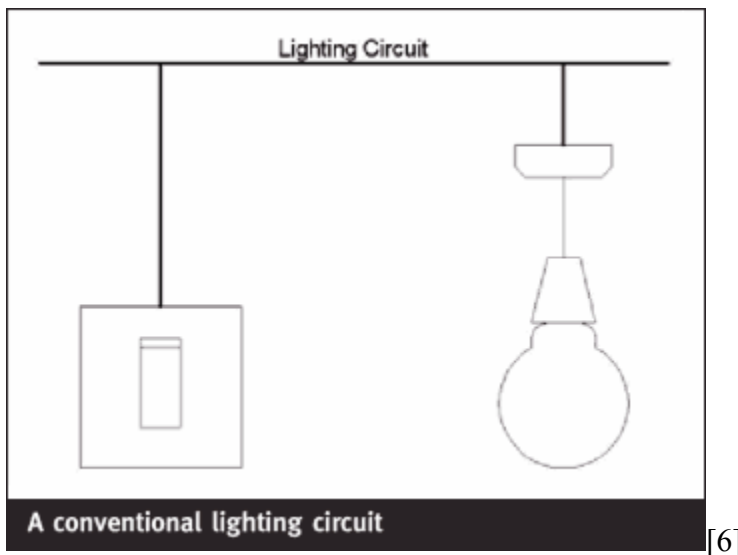

In the smart home the switch takes on a much different function. Instead of electronically “telling” the light bulb to turn on it passes a signal to the central bus

system. A bus is “is a dedicated wiring system installed purely for the purposes of distributing information.”

The bus will then propagate this signal along the network to controllers that are hooked up to a light fitting, or an appliance. This controller will either ignore the signal or recognize that it is meant for it and will respond in the correct manner; in the case of the light bulb it would send enough electricity to turn it on. The diagrams below show how this is set up. The bottom diagram has it set up so that all of the 4 things are using the same controller, which is possible, it will just have to be a little smarter and be able to understand more complex signals.

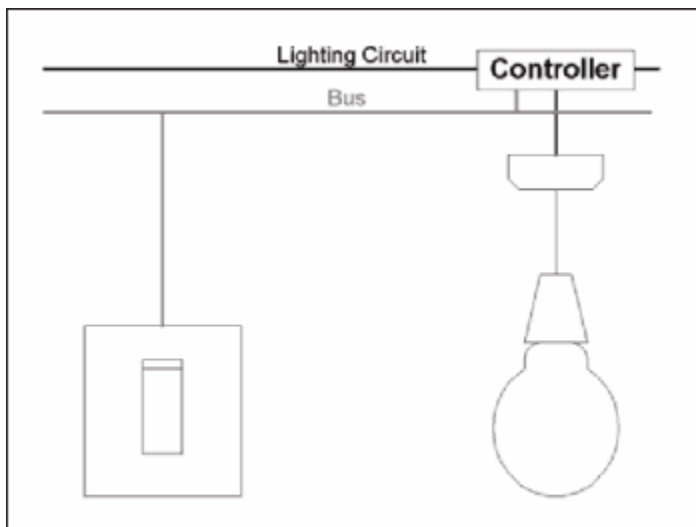

A bus system controlling a lighting circuit

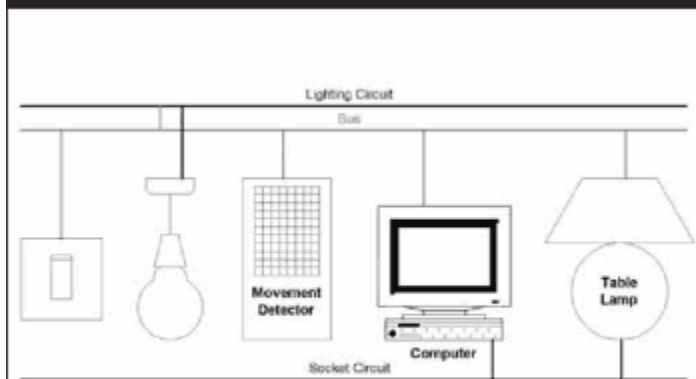

A bus system connecting a variety of devices

[6]

The bus will not only allow the switches to send signals but it will also allow the appliances to send signals to the other appliances that will make them do certain things. For example, the alarm clock is plugged into to an outlet that is hooked up to the bus. When it goes off it could send a signal through the bus that would tell the coffee machine (also connected to the bus) to start making coffee.

### **Parts of a Smart House**

Once a house has a central computer and the special wiring it has the capability to be a smart house. However, the house is not really “smart” until it becomes automated, either fully, or partially. There are several different things that a house can have automated. The most important of these are: energy management, lighting, security, appliances, emergency management, and entertainment. [5]

### **Energy Management**

One of the most interesting aspects of a smart home is that it is, or can be very energy efficient, and is very good at managing the energy used throughout the whole house. It does this by monitoring the usage and also the number of people in the house.

If no one is around then the house will lower the temperature setting and will turn off appliances or lights that will not be used, and are not needed. It can also manage the heaters, air conditioners and fans in such a way that will save energy. For example, if the temperature outside is only slightly more then the setting on the thermostat then the house can use the fans, instead of the air conditioner, which uses much more energy. [1]

Another way that the smart house saves energy is the fact that it can completely turn energy off to an outlet, if it is not in use. So if the TV is not in use then the house will turn the energy off to it, which will save a small amount of energy, which over time could end up saving a lot of money. According to some experts this methods could save up to 2/3 of ones energy bill every month. [5]

### **Lighting**

With a smart home there are several options that home owner can take that will improve the lighting in a house. Several of these options will make the house safer and easier to live in.

#### **Programmable Lights**

With a smart house the owner is able to program the lights to come on at certain times, or even dim them to match their mood. This is especially useful in terms of security. The owner can use the central computer and set certain lights to come on at seemingly random times during the night and stay on for a little while. This could be a major deterrent to criminals. [8]

#### **Remote Access**

One of the best things about a smart house is that the owner will be able to remotely control all of the lights in the house. For example, the owner could be sitting in the living room and suddenly remember that the lights in the kitchen were left on. They could pull out a PDA, or telephone and turn the lights off. This could even be done outside the home such as at a restaurant or at work. [8]

## **Security**

A house can be very valuable and often hard to protect, leading to a lot of break-ins every year. However, a smart home is much more secure and offers many features that the current houses on the market do not.

A smart home can use an alarm system that is very similar to the current car alarms. With a single push of a button, the house would enter “security mode” and all windows and doors would be closed and locked, and the security system turned on. [6]

This system while mostly used for single day uses, could also be programmed for long trips. The owner can set it to open the curtains, turn on and off the lights, and basically make it look like someone is still living there.

This system could then be turned off again by pushing the same button when the owner arrives home.

Another possible part of the security system is hidden surveillance cameras around the home. These can be checked by using an Internet connection and will allow the owner to check on pretty much every aspect of their home, and will let them know when a burglar enters or if the cat is “ruining” the furniture again, and then they can take appropriate actions. [8]

## **Smart Appliances**

One of the key components of a smart home are smart appliances. These appliances will be able to perform tasks that are not within their current job description, and all of this will be done using networking and the bus that the smart home provides.

[2]

For example, the coffeemaker can brew a pot of coffee before the owner even gets out of bed, the dishwasher has a sensor that knows how dirty the dishes are, and can select the appropriate cycle to clean them. By pushing a button, the refrigerator can adjust the temperature to the correct level based on the food within. [9]

While all of this sounds like an episode from the Jetsons, smart appliances are a big part of what a smart home, and many of these products are actually available now, with others expected to hit the market soon.

### **How Smart Appliances Work**

Smart appliances use mostly embedded circuitry and standard household lines or wireless technology to communicate. Using this circuitry the items, —a coffeemaker, electric blanket, smoke detector, mixer, etc. —automatically network and communicate with each other when they are plugged in. [2]

All of the smart appliances are connected to a bus, which is what drives the communication of the network. The bus will allow the central computer or owner to turn on or off the devices, but it also allows the devices to turn each other on or off. For example, the alarm clock could tell the coffee machine to start up 10 minutes before it woke up, or if the fire alarm goes off, the alarm clock could go off as well in order to wake the owner up.

### **Emergency Management**

An emergency can be in many forms, often the family is confused and does not know what to do. A smart house can inform the family about what the emergency is and

then contact the proper authorities and let them know that something is wrong. There are two examples that show the capabilities of a smart house in an emergency.

The first is if there is a fire. The fire alarm would go off and the house would immediately call the fire department and inform them that there is a fire. Then it would turn on the lights that lead to an exit and unlock all the doors and windows, which would make it much easier for the family to escape.

The second example is if there is a gas leak of some kind. The house could detect this and immediately shut down the gas main and disable all electronic devices so that a spark would not be generated accidentally, then the house would sound an alarm to let the family know about the leak. [6]

In some more advanced versions of smart houses, ones that have voice automation, the house could tell the family what is going on and inform them of what to do.

### **Entertainment**

While offering very little of real value, one of the first things that homeowners automate in the home usually has something to do with entertainment. Often this is in the form of a home theater system or a network of computers. While this doesn't really make life any easier having an awe inspiring home theater system is something that many people really look forward to. This could include allowing the user to change channels by speaking, improved recording capabilities, and the ability to use the Internet in conjunction with the TV. [7]

However, why stop with one room. A smart house can be set up so that the owner could turn off a TV in another room, or even switch signals so that they could watch the show on another TV without the hassle of finding it again. [8]

## **Conclusion**

The smart home may sound like something from the future, but many examples are actually being built today, and in the near future the majority of new homes being built will be “smart”. The reason many new homes are being built smart is not only because of the conveniences they offer, but also the safety. Smart homes can provide incredible home security, provide a dynamite home theater system, and many of the things that people want or need to make their lives easier.

While all of this automation may scare some people, it is also very clear that the smart home will greatly improve the way of life. And in the very near future many of us may find ourselves enjoying the great luxury of a home that is not only a place to live, but also a place that makes life easier.

## **Bibliography**

1. Berman, Michael, 2004, Smart Homes [Online]  
Available: <http://www.computerbits.com/archive/2004/1000/smarthomes.html>
2. Blair, Pam, 2000, Home Appliances Get Smart [Online]  
Available:  
<http://home.europa.com/~ruralite/energy%20topics/kitchen%20gets%20smart.pdf>
3. Bonsor, Kevin, 2002, How Ubiquitous Computing Will Work [Online]  
Available: <http://www.howstuffworks.com/static/ubiquitous-network.htm>
4. Financial Services Fact book, 2003, Snapshot of Housing in America, 2002-2003  
[Online] Available:  
[http://www.financialservicesfacts.org/financial2/mortgage/homeown/?table\\_sort\\_734867=5](http://www.financialservicesfacts.org/financial2/mortgage/homeown/?table_sort_734867=5)
5. Koprowski, Gene, 2003, A Brilliant Future for the Smart Home [Online]  
Available: <http://www.technewsworld.com/story/31239.html>
6. Joseph Rowntree Foundation, 2003, Introducing Smart Homes [Online]  
Available: <http://www.jrf.org.uk/housingandcare/smarthomes>
7. MSN – House & Home, 2004, The Microsoft Home: The Ultimate 'Smart' Home with Personality [Online]  
Available: <http://houseandhome.msn.com/Improve/MicrosoftHome0.aspx>
8. MSN – House & Home, 2004, Smart Homes: Your Wish Is Their Command [Online]  
Available: <http://houseandhome.msn.com/Improve/SmartHomes0.aspx>
9. Smith, Eileen, 2000, Appliances Get Smart [Online]  
Available: <http://www.pcworld.com/news/article/0,aid,14789,00.asp>